

DESCRIPTION	
CODE	FINISH
38AGKIT1.2	GRATE : STAINLESS STEEL CHANNEL : PVC

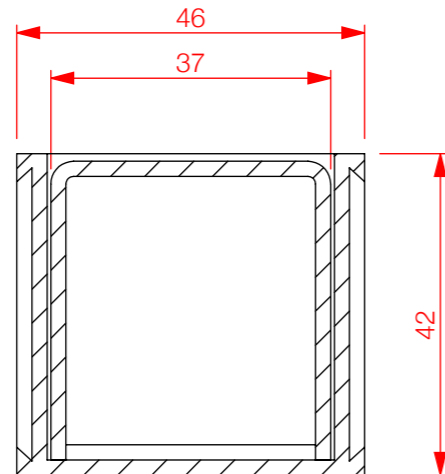

SECTION Q-Q  
SCALE 1 : 1

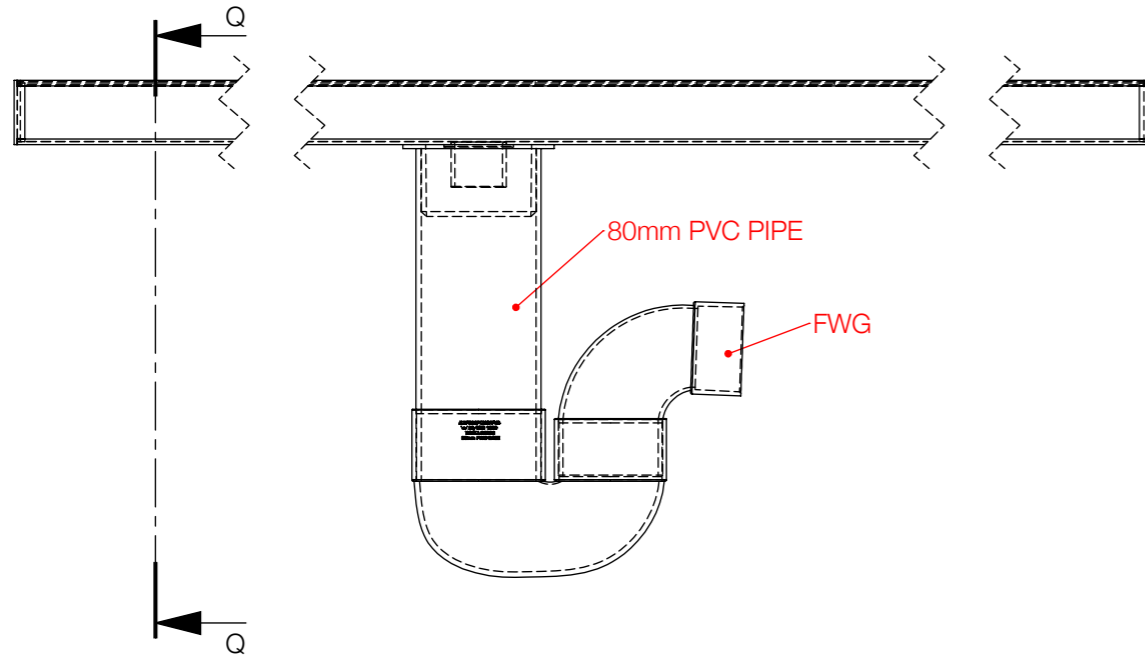
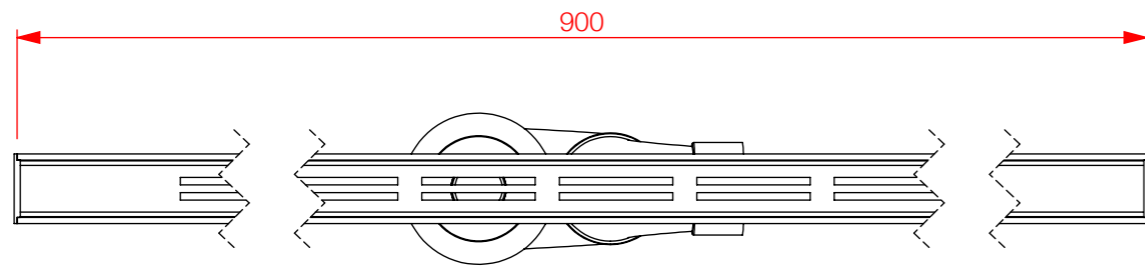
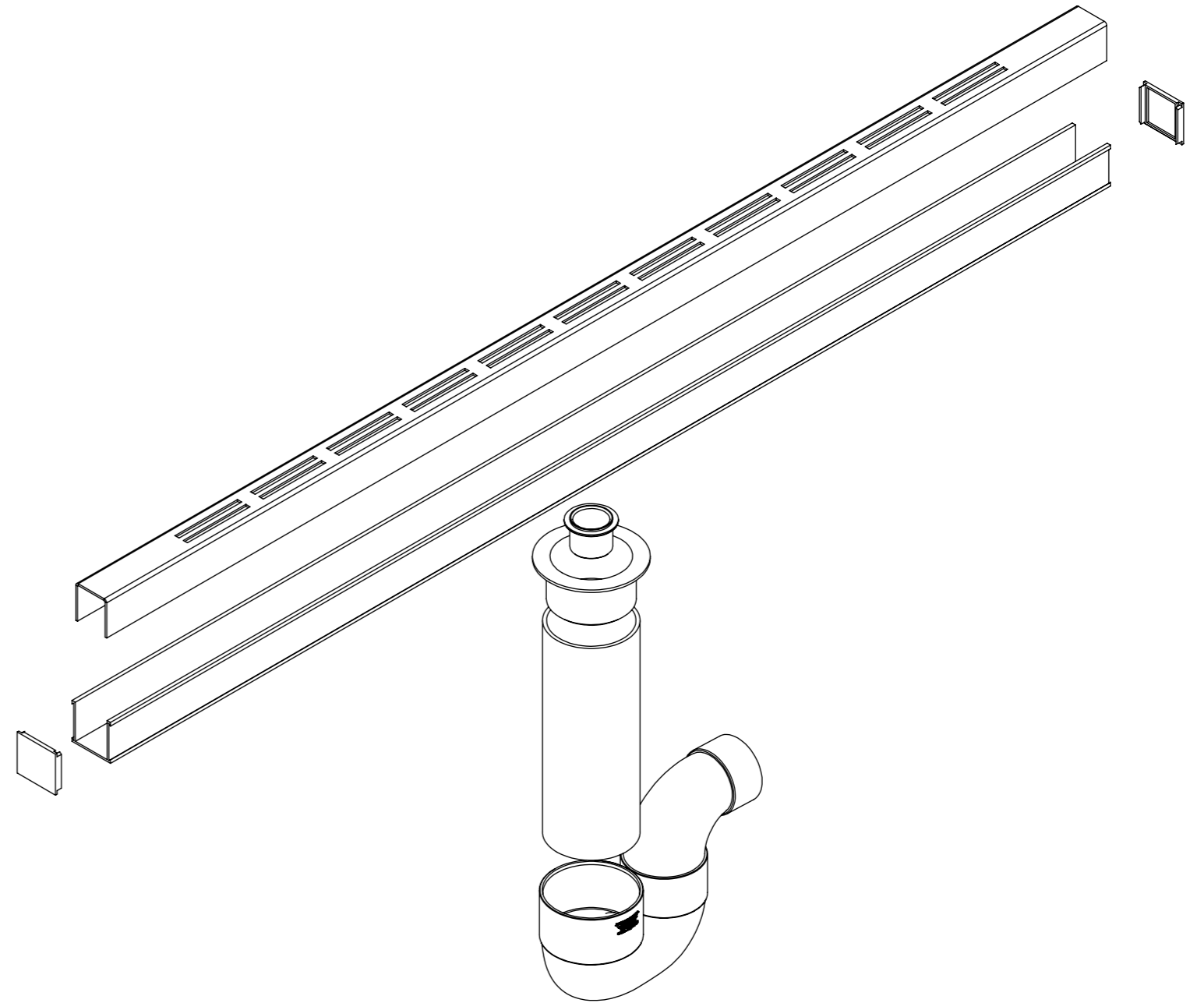

REVISION	CHANGE	DESCRIPTION	SL	DATE
XXX	XXX	XXX	SL	XXX
DO NOT SCALE DRAWING		TITLE		
REQUESTED	DATE	38mm X 900mm LAS BATHROOM KIT		
XXX	XXX			
DRAWN	DATE	APPLICABLE STANDARD(S):		
S.L.	XXX			
APPROVED	DATE	DRAWING REF NUMBER		
MATERIAL				
PVC/SS		SCALE (UOS) 1 : 5 & 1		
A3	UNITS = MM			
FILE S:\CAD FILES\2017\DIVERSE\SLIMLINE		SHEET 9 OF 10		

TOOL NUMBER	0.0
PART WEIGHT(GRAMS)	0.0
FILE	S:\CAD FILES\2017\DIVERSE\SLIMLINE

DISCLAIMER : THE DESIGN SUGGESTION IS PROVIDED FOR EVALUATION PURPOSES ONLY.  
IT IS NOT TO BE CONSIDERED A FULL DESIGN AS WE ARE NOT THE CONSULTING ENGINEERS, WE ARE MANUFACTURERS, WE ARE NOT PRIVY TO ALL THE INFORMATION PERTAINING TO THIS MATTER AND WE HAVE NO CONTROL OVER THE PROJECT INSTALLATION OF THE PRODUCT, THE DESIGN SUGGESTION IS PROVIDED WITHOUT OBLIGATION.  
DESIGN IS TO BE CONFIRMED AND APPROVED BY THE ARCHITECT, HYDRAULICS ENGINEER, OR PROJECT MANAGER. ACCURATE MEASUREMENTS SHOULD BE CONFIRMED BY THE PERSON APPROVING THE DESIGN. ALLPROOF ACCEPTS NO LIABILITY FOR THE IMPROPER USE OF THE DESIGN SUGGESTION.