

ALLPROOF INDUSTRIES VINYLRITE FLOOR WASTE SYSTEM 50MM VINYL/MEMBRANE FINISH CHROME FLOOR WASTE

Independent Flow Rate Test (Branz): 40 litres/minute under 25mm head of water

- Security Screw option available

Specification Code	Description	Standard Finish
VR50CP	50mm Vinyl Waste including PVC base flange, clamp ring and grate	Chrome on Brass clamp ring and grate
VR50NB	50mm Vinyl Waste including PVC base flange, nickel bronze clamp ring and grate	Finished Nickel bronze clamp ring and grate
VR50BR	50mm Vinyl Waste with PVC base flange, bronze clamp ring and grate	Finished Bronze clamp ring and grate

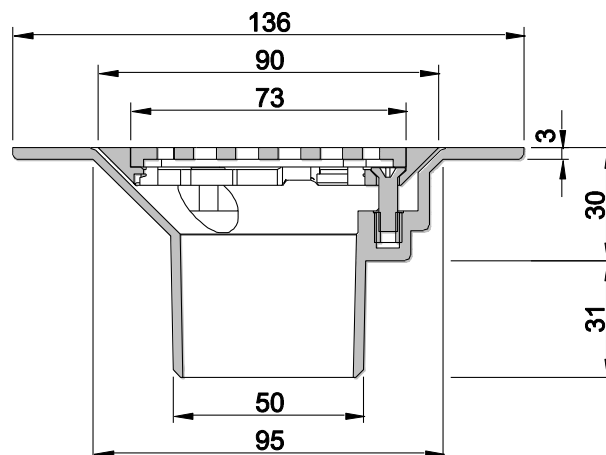
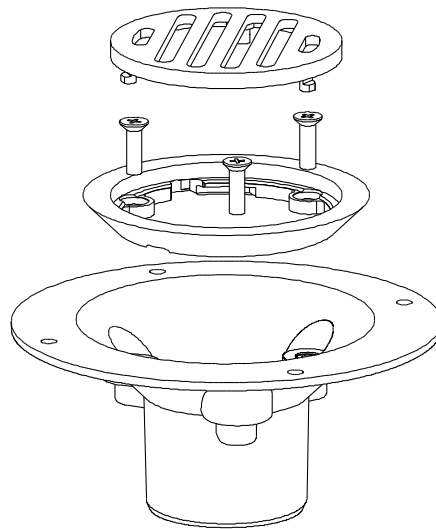

Due to Allproof Industries ongoing product development program product designs may be changed without notice