

ALLPROOF INDUSTRIES REVOLVER FLOOR WASTE 50MM VINYL FINISH EASY CLEAN CHROME FLOOR WASTE

FEATURES:

- Base flange features 4 countersunk holes for fastening to substrate and 3 stainless steel inserts
- Vinyl/waterproofing membrane clamped using 3 x stainless screws and clamp ring
- Cam-lock grate for easy waste access without disturbing vinyl/membrane
- Clamp Ring/grate feature a flush finish with flooring
- Fully revolving outlet for 50mm waste pipe exit from horizontal to vertical
- Easy clean funnel and bucket fully removable for cleaning and access to waste pipe
- Can also be used for tile applications

Specification Code	Description	Standard Finish
REVCPV	50mm Vinyl Easy Clean Waste including vinyl clamp ring and grate	Chrome on Brass clamp ring and grate

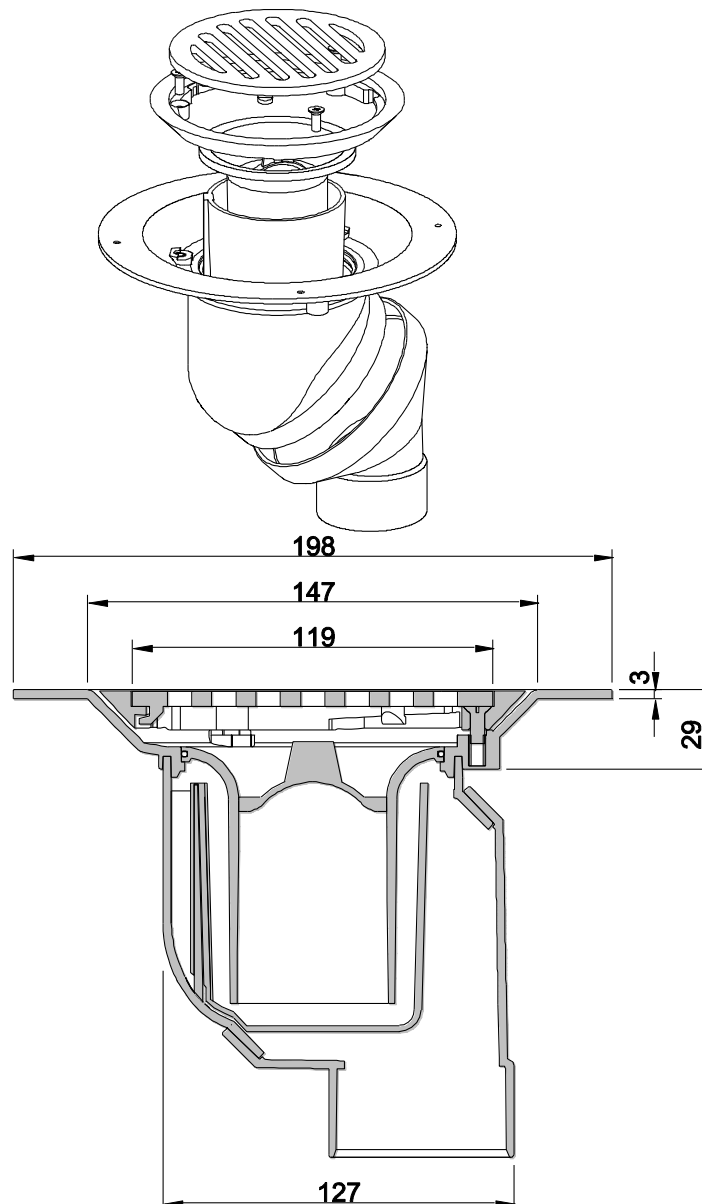

Due to Allproof Industries ongoing product development program product designs may be changed without notice.