

## ALLPROOF INDUSTRIES VINYLCLAMP RING FLOOR WASTE SYSTEM 100MM VINYL/MEMBRANE FINISH FLOOR WASTE

Independent Flow Rate Test (Branz): 89 litres/minute under 25mm head of water

- Security Screw option available

Specification Code	Description	Standard Finish
168.100VCR	100mm Vinyl Waste with bronze base flange, clamp ring and grate	Chrome on Brass clamp ring and grate
168.100VCR NB	100mm Vinyl Waste with bronze base flange, nickel bronze clamp ring and grate	Linished Nickel Bronze clamp ring and grate
168.100VCR SS	100mm Vinyl Waste with bronze base flange, stainless clamp ring and grate	Polished 304 Stainless Steel clamp ring and grate
168.100VCR BR	100mm Vinyl Waste with bronze base flange, bronze clamp ring and grate	Linished Bronze clamp ring and grate

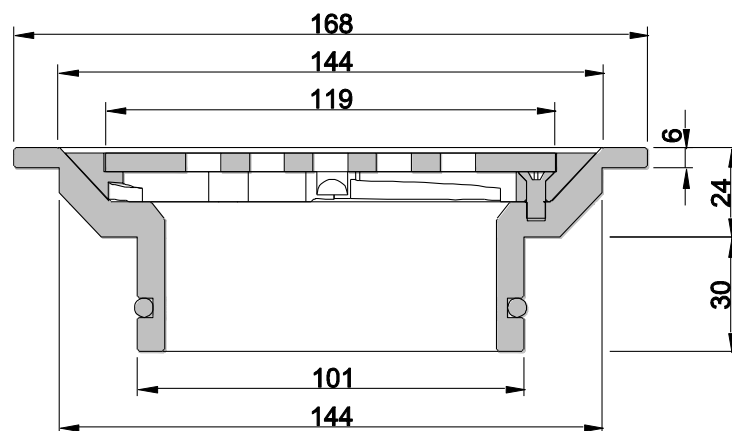
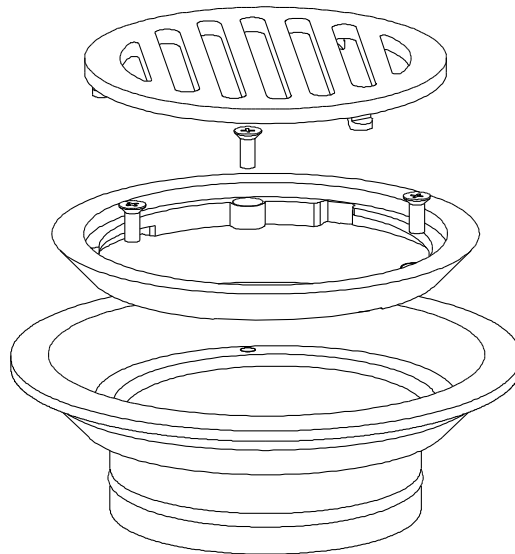

Due to Allproof Industries ongoing product development program product designs may be changed without notice