

ALLPROOF INDUSTRIES REVOLVER FLOOR WASTE 50MM TILE FINISH EASY CLEAN CHROME FLOOR WASTE

FEATURES:

- Base flange features 4 countersunk holes for fastening to substrate
- Easy cut height adjustable tile grate located using 3 lugs on flange allowing moisture to escape
- Fully revolving outlet for 50mm waste pipe exit from horizontal to vertical
- Easy clean funnel and bucket fully removable for cleaning and access to waste pipe
- Can also be used for vinyl applications

Specification Code	Description	Standard Finish
REVSCPT	50mm Tile Easy Clean Waste including square chrome/brass tile grate	Chrome on Brass grate
REVRCP	50mm Tile Easy Clean Waste including round chrome/brass tile grate	Chrome on Brass grate
REVINVCP	50mm Tile Easy Clean Waste including square chrome invis-drain grate	Chrome on plastic grate
REVINBRCP	50mm Tile Easy Clean Waste including square chrome invis-drain grate	Chrome on Brass grate

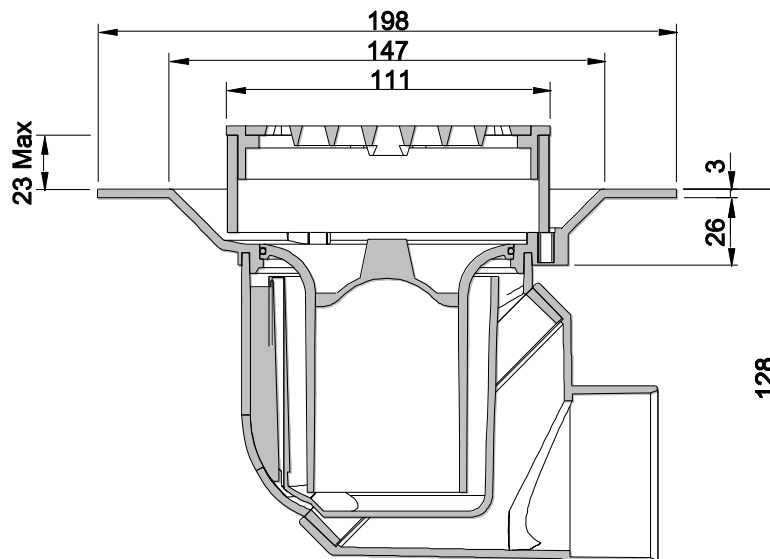
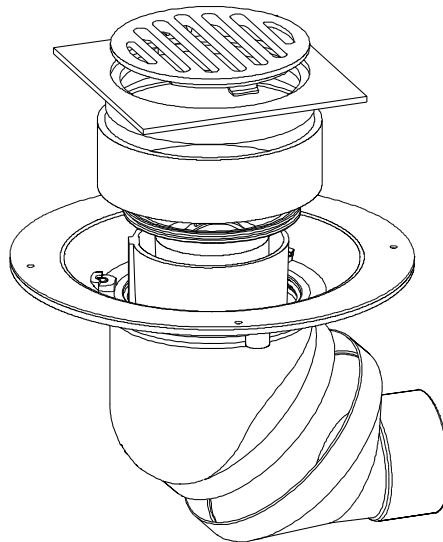

Due to Allproof Industries ongoing product development program product designs may be changed without notice.