

## ALLPROOF INDUSTRIES TILE INSERT FLOOR WASTE SYSTEM 100MM TILE FINISH LEAK CONTROL FLANGE AND INVISI-DRAIN GRATE

### FEATURES:

- LC-100 PVC leak control flange fits inside 100mm pipe riser
- Flange features locating lugs for grate and provides a bonding surface for waterproofing
- Locating lugs allow sub-tile moisture to escape though DWV system
- A tile insert is cut and adhered into the tile tray
- INVISI-DRAIN grate features height adjustable plastic spigot
- Drainage is between the tile frame and tile tray, making it an INVISI-DRAIN
- Grate Finish Options: Chrome on Brass, Grey Plastic, Chrome on Plastic

Specification Code	Description	Standard Finish
INVISI-100BRCP	100mm PVC leak control flange and square invisidrain floor grate	Chrome on Brass
INVISI-100CP	100mm PVC leak control flange and square invisidrain floor grate	Chrome on Plastic
INVISI 100	100mm PVC leak control flange and square invisidrain floor grate	Grey Plastic

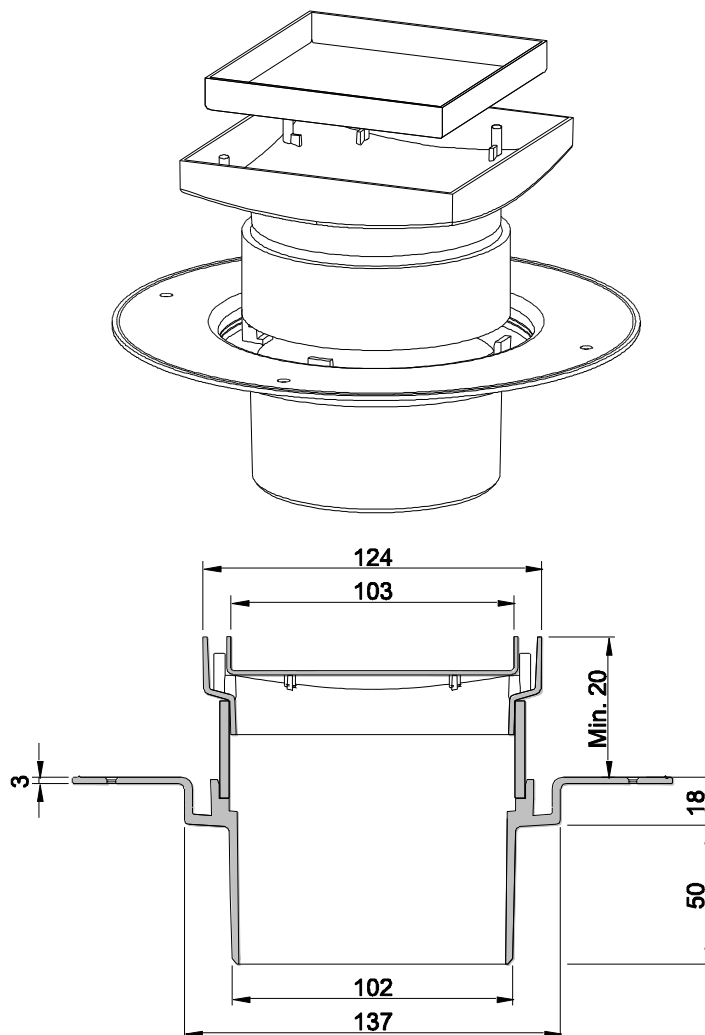

Due to Allproof Industries ongoing product development program product designs may be changed without notice