

ALLPROOF INDUSTRIES DOUBLE STRAIN STORM DRAIN 150MM SQUARE DRAIN WITH DOUBLE SEDIMENT BASKET AND 100MM OUTLET

FEATURES:

- Primary and Secondary 304 Stainless Steel Strainer baskets substantially reduce the amount of solid waste entering drainage system
- Primary basket is secured in Drain body while the Secondary basket is removable for cleaning
- Durable cast construction with o-ring seal inside pipe ideal for commercial/industrial areas
- Removable or Hinged grate for easy access and fastened in place with screws
- Stainless Steel and Nickel Bronze Finish Options: Linished (L), Polished (P), Hinged Grate (H), Security Screws (S)
- Independent Flow Rate Test For Drain (Branz): 121 litres/minute under 25mm head of water

Specification Code	Description	Standard Finish
168.150.100SSS/SNB DS H	150mm Square double strained storm drain with 100mm outlet	Polished SS or Nickel Bronze, Hinged Grate

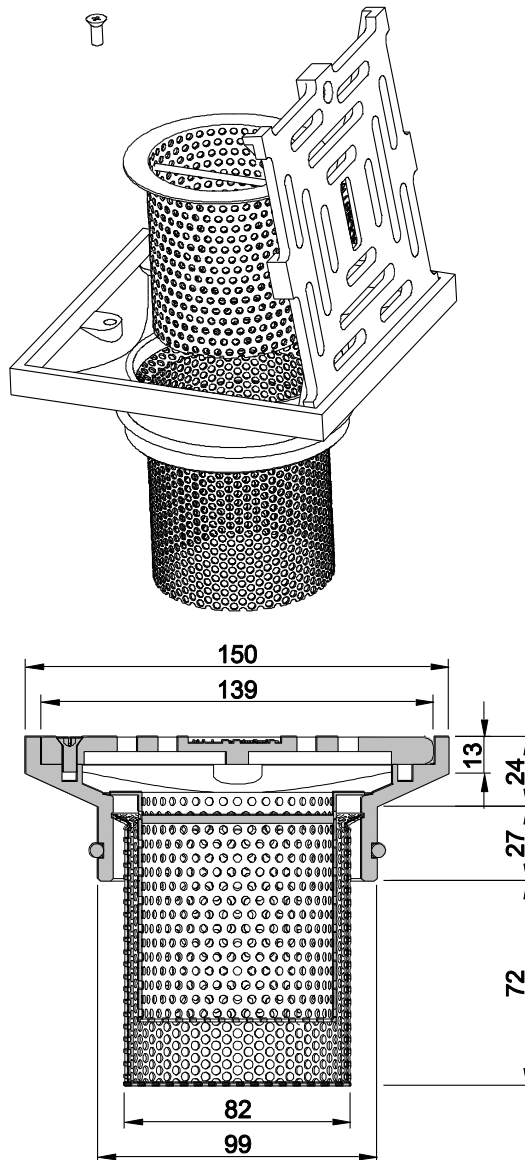

Due to Allproof Industries ongoing product development program product designs may be changed without notice