

## ALLPROOF INDUSTRIES DOUBLE STRAIN VINYL DRAIN 100MM VINYL/MEMBRANE DRAIN WITH DOUBLE SEDIMENT BASKET

### FEATURES:

- Primary and Secondary 304 Stainless Steel Strainer baskets substantially reduce the amount of solid waste entering drainage system
- Primary basket is secured in Drain body while the Secondary basket is removable for cleaning
- Durable cast construction with o-ring seal inside pipe ideal for commercial/industrial areas
- Removable grate for easy access and fastened in place with screws
- Stainless Steel and Nickel Bronze Finish Options: Linished (L), Polished (P), Security Screws (S)
- Independent Flow Rate Test For Drain (Branz): 89 litres/minute under 25mm head of water

Specification Code	Description	Standard Finish
168. 100VCR SS/NB DS	100mm double strained vinyl clamp ring drain	Polished SS or Linished Nickel Bronze

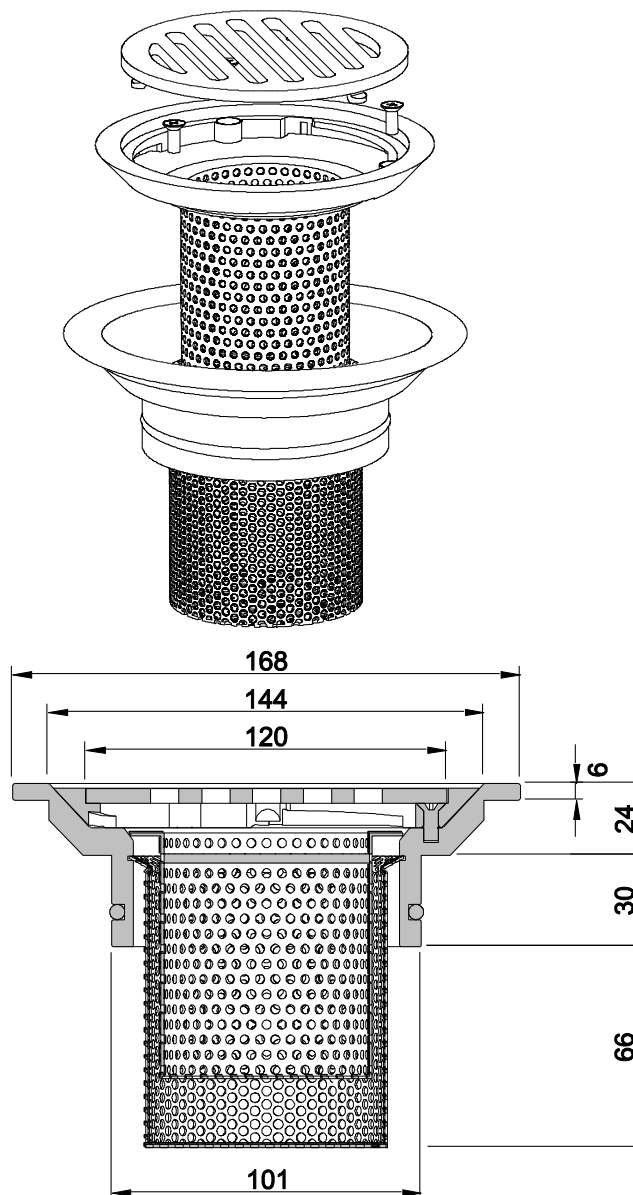

Due to Allproof Industries ongoing product development program product designs may be changed without notice