

ALLPROOF INDUSTRIES TAMPERPROOF SECURITY FLOOR DRAIN 50MM FOR VINYL/MEMBRANE FINISH IN HIGH RISK INSTITUTIONAL AREAS

Specification Code	Description	Standard Finish
168.50VCR SEC- 90°	50mm security drain including bronze base flange, clamp ring and tamperproof grate	Nickel Bronze clamp ring and Grate

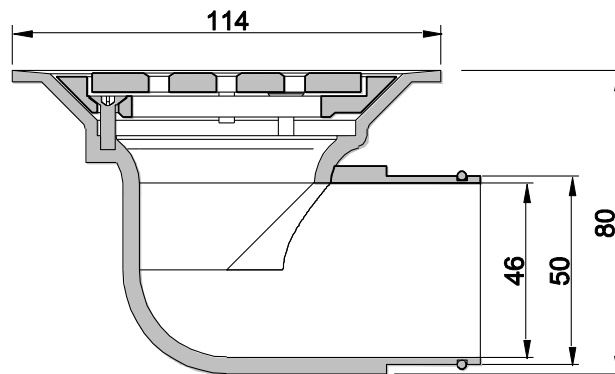
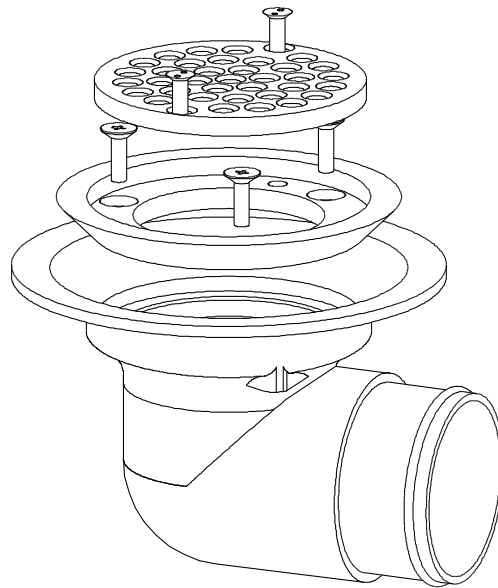

Due to Allproof Industries ongoing product development program product designs may be changed without notice