

## ALLPROOF INDUSTRIES TAMPERPROOF SECURITY FLOOR DRAIN 100MM FOR CONCRETE FINISH IN HIGH RISK INSTITUTIONAL AREAS

Specification Code	Description	Standard Finish
168.100SECNB	100mm Round security drain	Finished Nickel Bronze
168.100SECB	100mm Round security drain	Finished Bronze

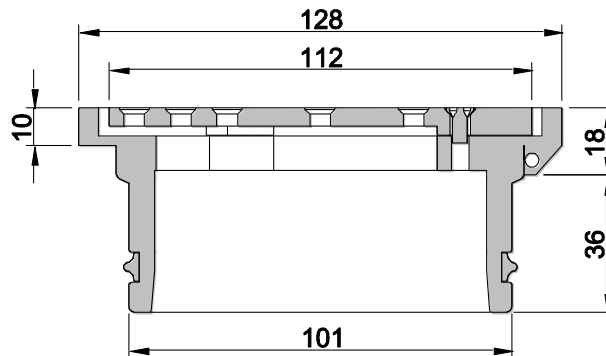
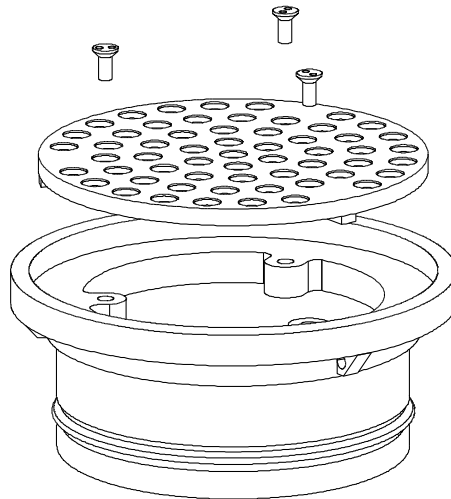

Due to Allproof Industries ongoing product development program product designs may be changed without notice