

ALLPROOF INDUSTRIES DOMED SMALL DIAMETER CLAMP RING DRAIN 65MM MEMBRANE FINISH GUTTER OUTLET

Specification Code	Description	Standard Finish
168.65DCR	65mm Domed drain including bronze base flange, clamp ring and dome	Cast Bronze clamp ring and dome

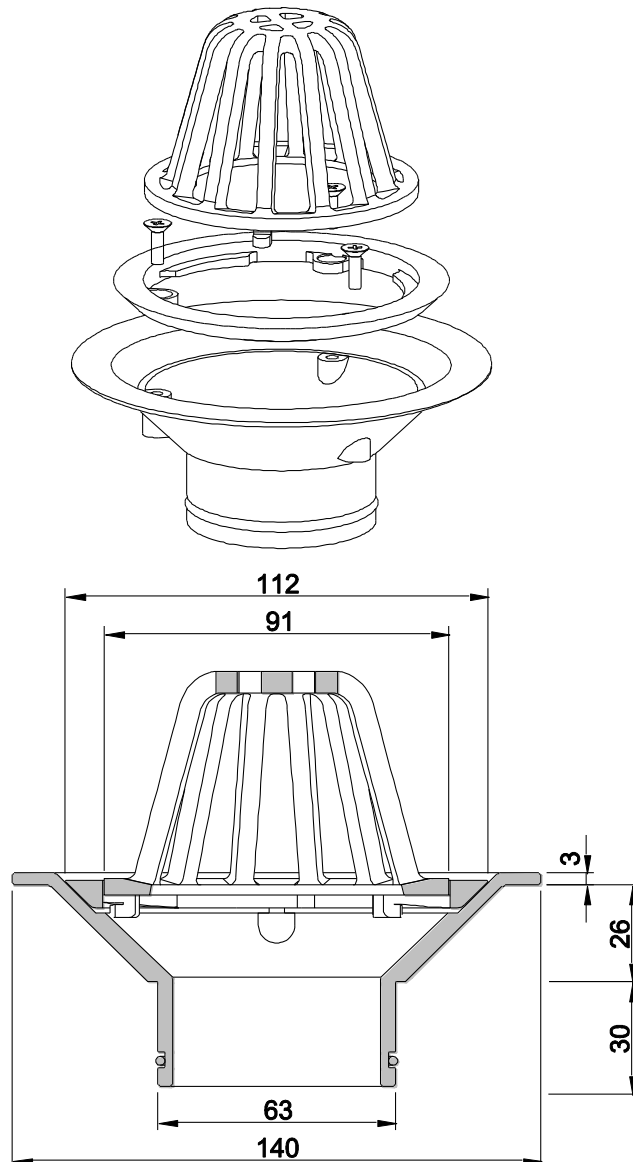

Due to Allproof Industries ongoing product development program product designs may be changed without notice