

**ALLPROOF INDUSTRIES DOMED SMALL DIAMETER CLAMP RING DRAIN
100MM MEMBRANE FINISH GUTTER OUTLET**

Independent Flow Rate Test (Branz): 165 litres/minute under 50mm head of water

Specification Code	Description	Standard Finish
168.100DCR	100mm Domed drain including bronze base flange, clamp ring and dome	Cast Bronze clamp ring and dome

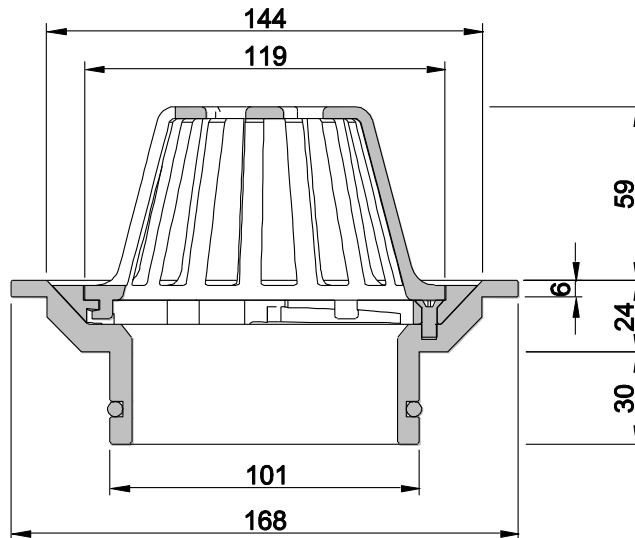
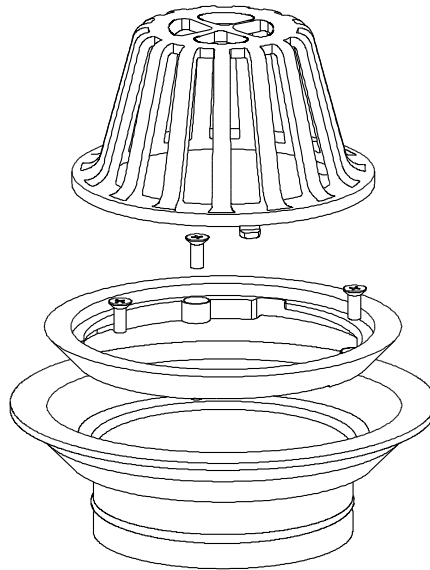

Due to Allproof Industries ongoing product development program product designs may be changed without notice