

## ALLPROOF INDUSTRIES BRONZE CLEAN OUT 100MM CONCRETE/TILE FINISH INSPECTION

Specification Code	Description	Standard Finish
168.100BCO	100mm cast bronze clean out including o-ring seal	Machined bronze
168.100BCO CP	100mm chrome plated cast bronze clean out including o-ring seal	Chrome on bronze
168.100BCO NB	100mm chrome plated cast nickel bronze clean out including o-ring seal	Machined Nickel bronze

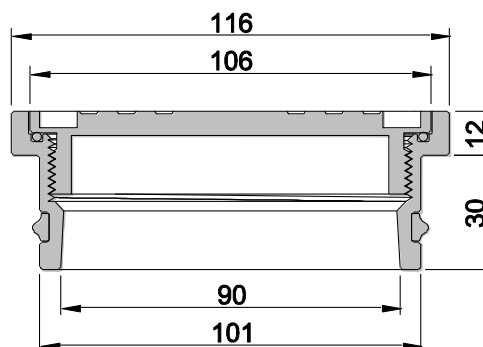
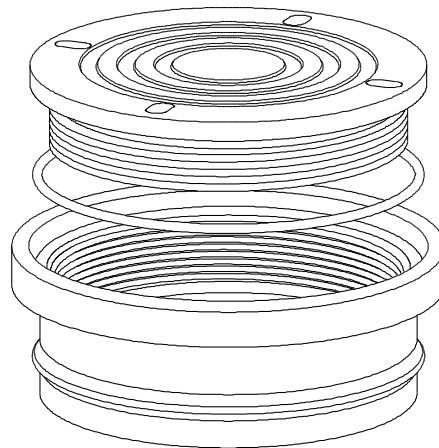

Due to Allproof Industries ongoing product development program product designs may be changed without notice